

气缸总成

CYLINDER HEAD ASSY

序号	代码		数量	备注
NO	CODE	DESCRIPTION	QTY	RMK
1	T3E01030010	HEAD , CYLINDER	1	
2	T3E01030020	GASKET , CYLINDER HEAD	1	
3	T3E01132000	SPEAK PLUG	1	NGK BR8ES (或BR7ES)
4	T3E01040010	CYLINDER	1	3XY00 49cm3
5	T3E01040020	GASKET , CYLINDER	1	非石棉
6	T3E01011060	STUD BOLT	4	镀铜
7	GB/T6177.1- 2000	NUT M7	4	不锈钢(30/45KM)
		NUT M7	3	不锈钢(25KM)
	T3E01030030	NUT	1	不锈钢 (只用于25KM版)

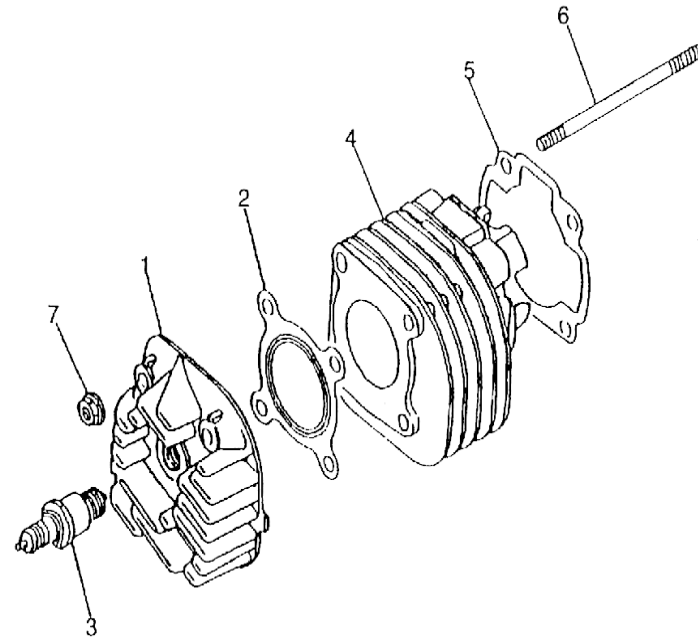

曲轴箱分总成

CRANKCASE ASSY

序号	代码		数量	备注
NO	CODE	DESCRIPTION	QTY	RMK
1	T3E01011010	CRANKCASE,LH	1	
2	T3E01011210	GROMMT	1	
3	T3E01011200	BEARING 6003	2	
4	T3E01012010	CRANKCASE,RH	1	
5	T3E01092020	BRAKE SHOE ANCHOR PIN ASSY	1	
6	T3E01011090	DOWEL PIN 12X16	2	
7	GB/T5787-1986	PAN HEAD SCREW M6X35	6	镀彩锌
8	T3E01011140	AXLE,engine mount	1	镀彩锌
9	GB/T894.1-1986	CIRCLIP 17	2	
10	T3E01011130	GASKET,L CRANKCASE	1	非石棉
11	T3E01020010	L CRANKCASE COVER	1	
12	T3E01020020	IDLE GEAR	1	
13	T3E01011100	DOWEL PIN 10X14	2	
14	GB/T5787-1986	PAN HEAD SCREW M6X25	8	不锈钢
15	GB/T5787-1986	PAN HEAD SCREW M6X35	1	不锈钢
16	GB/T5787-1986	PAN HEAD SCREW M6X65	1	不锈钢
17	T3E01011070	OIL PLUG	1	黑色
18	T3E01011220	O RING	1	
19	GB/T5787-1986	FLANGE BOLT M8X16	1	不锈钢
20	T3E01011270	PLATE WASHER	1	紫铜
21	T3E01012020	OIL SEAL HOLDER	1	
22	GB/T5787-1986	PAN HEAD SCREW M6X12	1	镀彩锌
23	T3E01012030	GASKET	1	非石棉

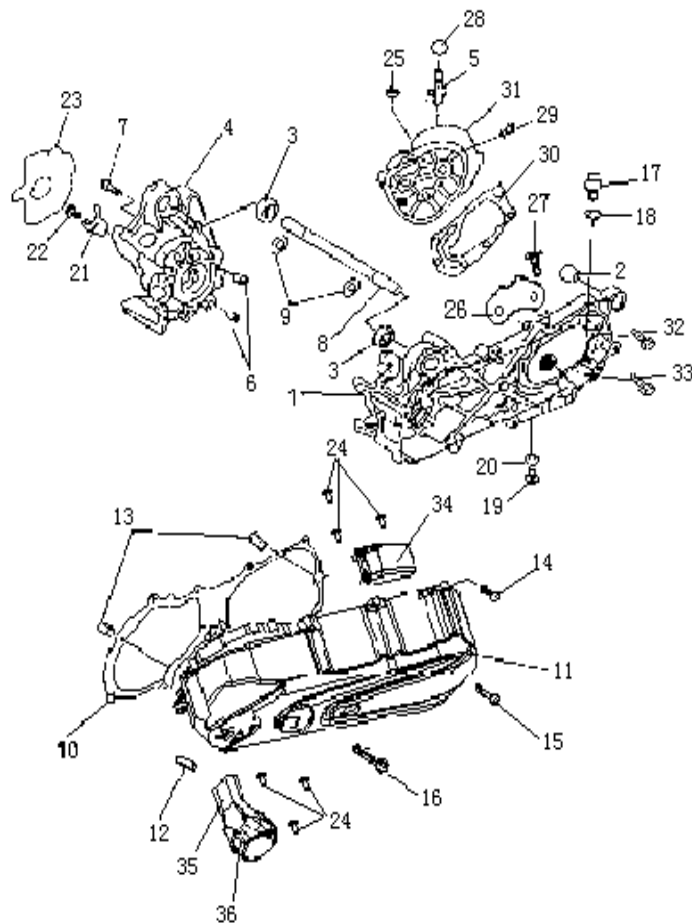

曲轴箱分总成

CRANKCASE ASSY

序号	代码		数量	备注
NO	CODE	DESCRIPTION	QTY	RMK
24	GB/T845-1985	SCREW ST3.5X14	6	镀铬
25	GB/T6187.1-2000	NUT M8	1	镀彩锌
26	T3E01011160	BEARING HOLDER	1	
27	GB/T5787-1986	PAN HEAD SCREW M6X12	2	镀彩锌
28	T3E01092060	O-RING	1	
29	T3E01011090	DOWEL PIN 12X16	2	
30	T3E01011120	MISSION CASE GASKET	1	非石棉
31	T3E01092010	MISSION CASE	1	
32	GB/T5787-1986	SCREW M8X55	2	不锈钢
33	GB/T5787-1986	SCREW M8X50	5	不锈钢
34	T3E01020110	AIR DUCT-OUTLET	1	
35	T3E01020100	AIR DUCT-INLET	1	
36	T3E01020130	FILTER ASSY	1	

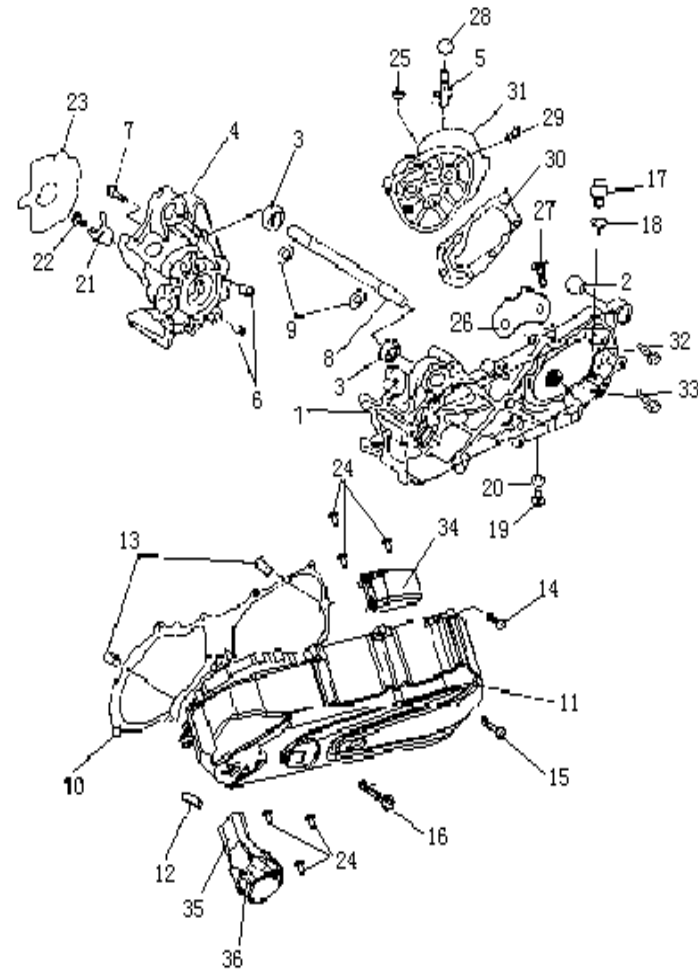

活塞连杆曲轴分总成
PISTON CRANKSHAF

序号	代码	数量	备注
NO	CODE	QTY	RMK
1	T3E01051000	1	CRANKCHAFT , ASSY
2	T3E01051010	1	CRANKSHAFT , LH
3	T3E01051030	1	CRANK PIN
4	T3E01051060	1	NEEDLE BEARING
5	T3E01051040	1	SONNECTING SHAFT
6	T3E01051020	1	CRANKSHAFT , RH
7	T3E01050050	1	WOODRUFF KEY 3X5X13
8	T3E01051050	2	NEEDLEBEATRING6204/P53
9	T3E01011190	1	OIL SEAL 20X42X8
10	T3E01012040	1	OIL SEAL ASSY 20X30X6
11	T3E01013020	1	COLLAR
12	T3E01052010	1	PISTON ASSY
13	T3E01050010	1	PISTON PIN
14	T3E01052020	2	PISTON RING ASSY
15	T3E01050020	2	CIRCLIP
16	T3E01050060	1	NEEDLE BEARING
17	GB893.1-1986	1	CIRCLIP 43

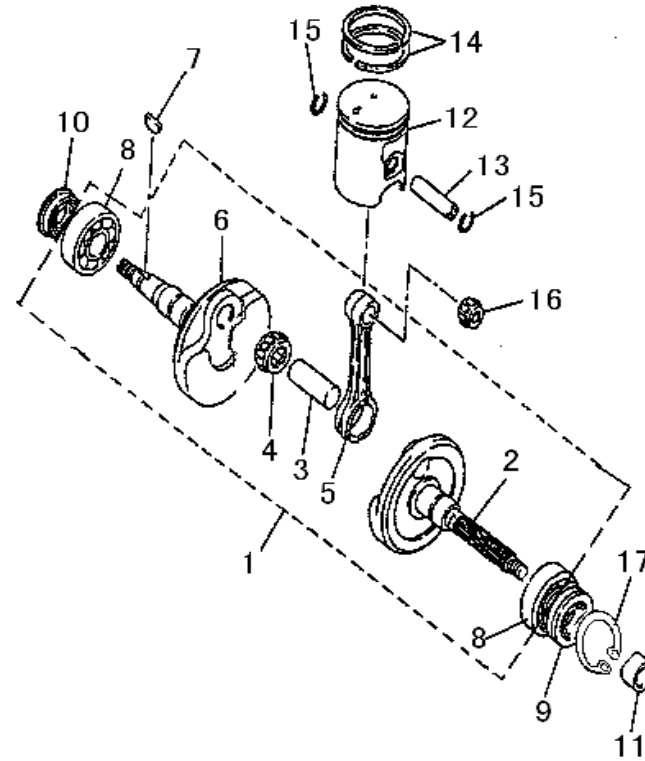

机油泵分总成

OIL PUMP ASSY

序号	代码	DESCRIPTION	数量	备注
NO	CODE	DESCRIPTION	QTY	RMK
1	T3E01070000	OIL PUMP ASSY 502	1	
2	GB/T818-2000	SCREW M4X8	1	
3	T3E01071010	WASHER 5	1	
4	T3E01071020	O-RING 19X1.8	1	
5	T3E01071030	GEAR	1	
6	T3E01071080	PIN 3X12	1	
7	GB896-86	CIRCLIP 8	1	
8	T3E01071040	HOSE	1	360
9	T3E01071050	HOSE CLIP	2	镀白锌
10	T3E01071060	HOSE	1	280
11	T3E01071070	HOSE CLIP	1	镀白锌
12	GB/T894.1-1986	CIRCLIP 19	2	
13	GB9074.4-1988	SCREW M5X16	2	
14	T3E01050040	PUMP DRIVE GEAR	1	
15	T3E01050030	PIN C3X14	1	

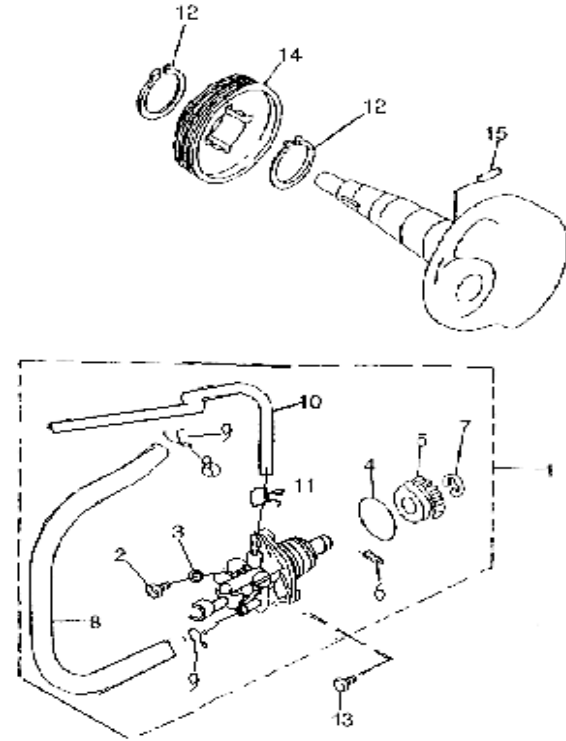

导风罩分总成

AIR COOLING SYSTEM

序号	代码		数量	备注
NO	CODE	DESCRIPTION	QTY	RMK
1	T3E01100030	COWLING,cylinder	1	
2	T3E01011110	GROMMET	2	
3	T3E01100020	COELING,fan	1	
4	GB/T5787-1986	BOLT M6×20	2	不锈钢
5	GB/T15856.4-95	SCREW ST5.5×40-F	1	不锈钢
6	T3E01100010	FAN ASSY	1	
7	T3E01100040	RUBBER RING 70X3.1	1	
8	GB9074.4-1988	SCREW M6×16	3	镀彩锌
9	GB/T93-87	WASHERΦ6	3	
10	GB/T95-85	WASHERΦ6	3	
11	T3E01100050	PLATE	1	
12	T3E01100060	MOLD,cowling	1	220
13	T3E01100070	COLLOR	3	
14	T3E01100080	COVER	1	
15	GB/T820-2000	SCREW M4X35	3	不锈钢
16	T3E01100060	MOLD,cowling	1	110

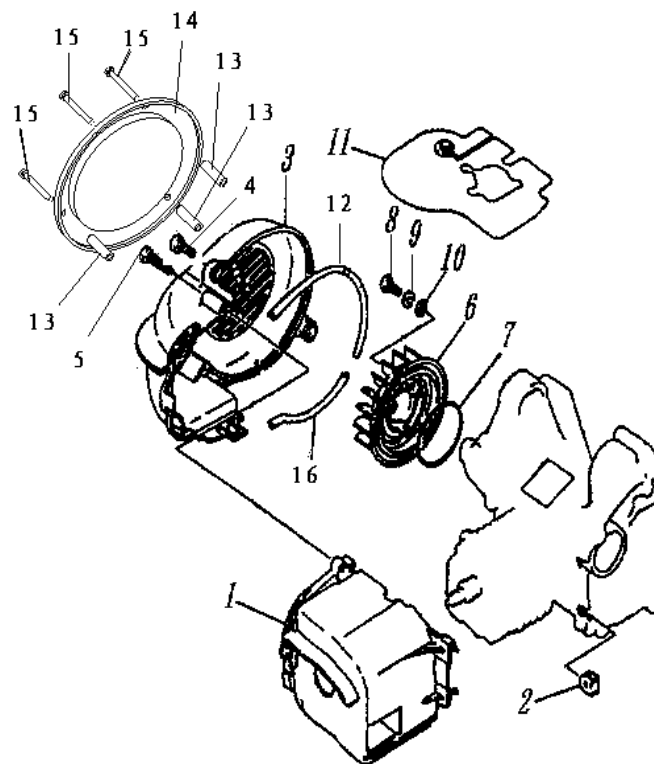

起动机总成

KICK STARTER ASSY

序号	代码		数量	备注
NO	CODE	DESCRIPTION	QTY	RMK
1	T3E01011030	START GEAR ASSY	1	
2	T3E01013100	NEEDLE BEARING	1	
3	T3E01013030	THRUST WASHER	1	
4	T3E01013000	START CLUTCH ASSY	1	
5	T3E01011040	IDLE GEAR	1	
6	T3E01011030	IDLE GEAR SHAFT		
7	T3E01011290	PLATE WASHER 8X16X2.5	1	
8	T3E01011050	IDLE GEAR HOLDER	1	
9	GB/T5787-1986	SCREW M6×10	2	镀彩锌
10	GB/T70.1-2000	SCREW M6×20	2	不锈钢
11	T3E01020060	SHAFT, kick starter	1	
12	T3E01020070	SPRING	1	
13	T3E01020080	BUSH	1	
14	T3E01020120	WASHER ,kick starter	1	
15	GB/T894.1-1986	CIRCLIP 15	1	
16	T3E01020030	KICK PINION ASSY	1	
17	T3E01020040	CLIP	1	
18	T3E01080000	STARTING MOTOR ASSY	1	镀铬
19	T3E01080010	O-RING 21.2X2.65	1	
20	T3E01011280	PLATE WASHER 8X16X1	1	
21	T3E01013040	COVER	1	
22	T3E01013050	PLASTIC RING	1	
23	T3E01013080	SPRING	3	
24	T3E01013070	CAP	3	
25	T3E01013060	ROLLER	3	

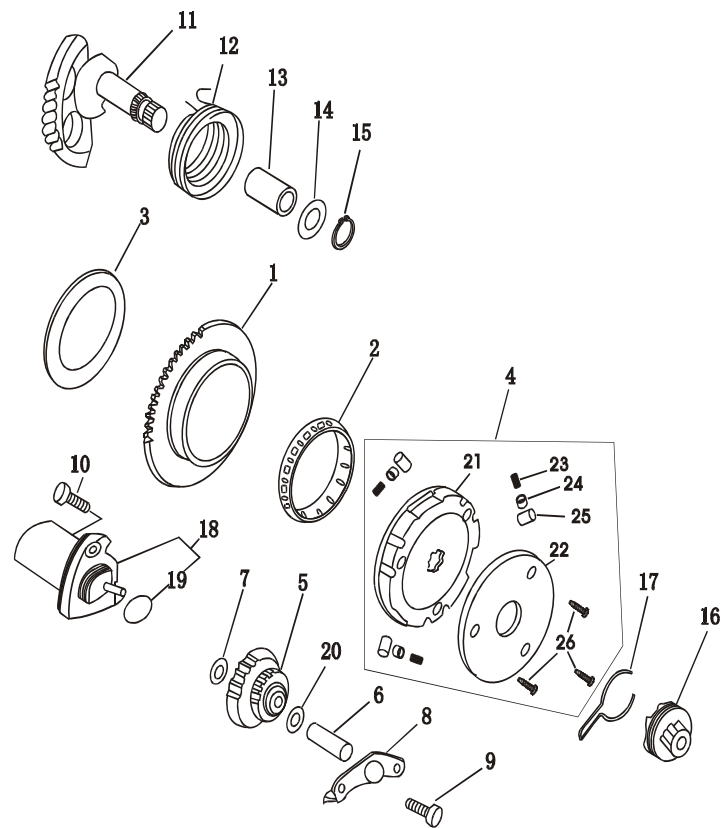

26	GB/T15856.4-95	TAPPING SCREW ST4.8x11	3	
----	----------------	------------------------	---	--

传动机构总成

CLUTCH ASSY

序号	代码	数量	备注
NO	CODE	QTY	RMK
1	QOA01011150	1	PRIMARY DRIVE GEAR
2	T3E01091000	1	DRIVEN PULLEY and CLUTCH ASSY
3	T3E01090060	1	宽度8.2 (25KM)
		1	宽度4 (30KM)
		1	宽度3.2 (45KM)
4	GB/T894.1-1986	1	CIRCLIP 17
5	T3E01011180	1	ROLING BEARING 6203
6	T3E01011170	1	OIL SEAL 17X35X7
7	T3E01091080	1	CLUTCH ASSY,shoe
8	T3E01091060	3	SPRING
9	T3E01091100	1	NUT M28X1
10	T3E01091090	1	HOUSING
11	GB/T6173-2000	1	NUT M10X1
12	T3E01090150	1	O-RING 6.7X3
13	T3E01020090	1	BEARING 638Z
14	T3E01090030	1	FACE,movable drive 带凸台II2
15	T3E01090040	6	重6.3g (25/30/45KM)
		6	重5.8g (58KM)
16	T3E01090010	1	PLATE,movable drive

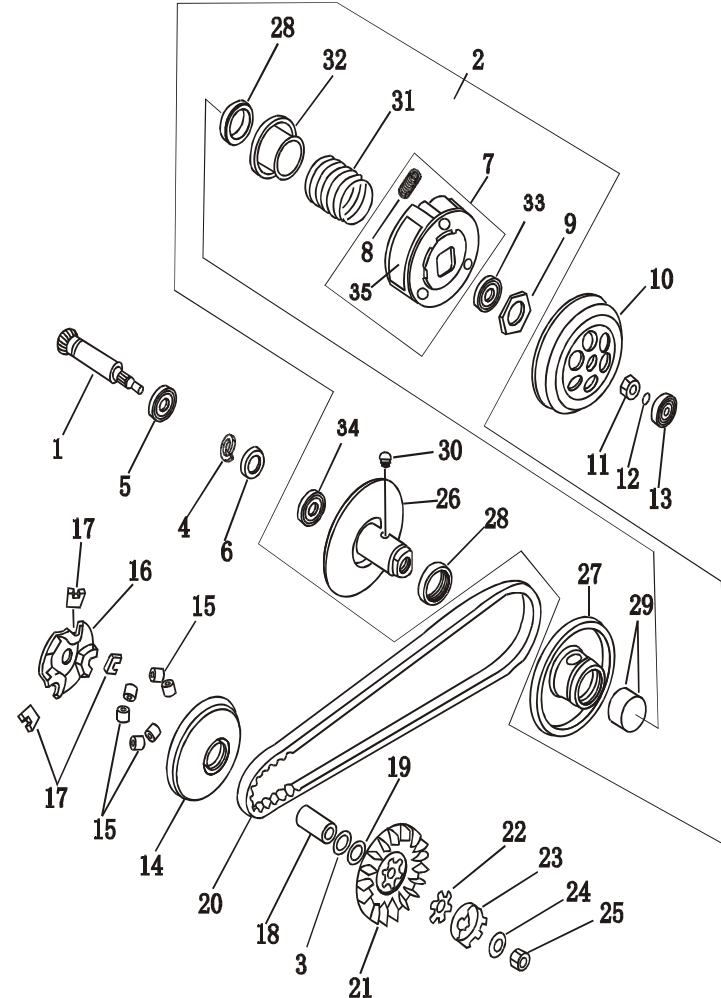

传动机构总成

CLUTCH ASSY

序号	代码	DESCRIPTION	数量	备注
NO	CODE	DESCRIPTION	QTY	RMK
17	T3E01090020	DAMPER	3	
18	T3E01090050	COLLER	1	
19	T3E01090160	WASHER	1	
20	T3E01090100	V BELT , DRIVE	1	
21	T3E01090070	FACE , FIXED DRIVE	1	蓝漆III2
22	T3E01090080	PLATE , WOODRUFF KEY	1	
23	T3E01090090	STARTING DISC	1	
24	T3E01090180	WASHER , SPRING	1	
25	GBT6171-2000	NUT M12X1.25	1	镀彩锌
26	T3E01091010	FACE , FIXED DRIVEN	1	
27	T3E01091020	FACE , MOVABLE DRIVEN	1	
28	T3E01091110	OIL SEAL 33X39X4	1	
29	T3E01091120	O-RING 1.7×38.7	2	
30	T3E01091050	PIN , GUIDE	1	
31	T3E01091040	SPRING	1	
32	T3E01091030	SEAT , SPRING	1	
33	T3E01091130	ROLLER BEARING	1	
34	T3E01091140	NEEDLE BEARING	1	
35	T3E01091070	SHOE	3	

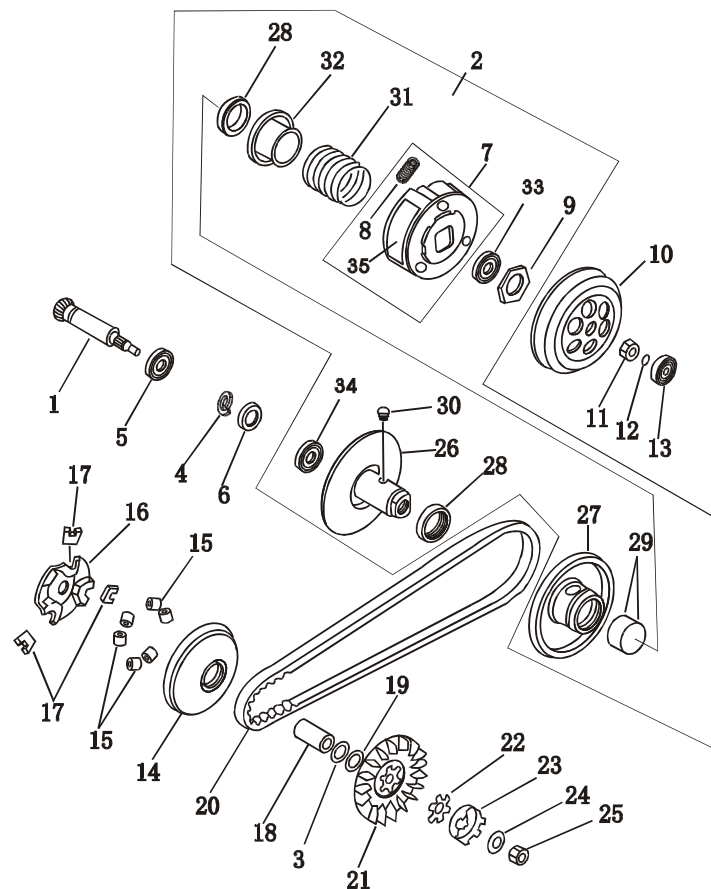

变速系统分总成

TRANSMISSION SYSTEM ASSY

序号	代码	数量	备注	
NO	CODE	DESCRIPTION	QTY	RMK
1	T3E01090110	SHAFT , IDLE	1	
2	T3E01092030	BEARING 6200	1	
3	T3E01090170	WASHER , thrust	1	
4	T3E01090130	SHAFT , REAR BOX	1	
5	T3E01092050	NEEDLE BEARING 6004	1	
6	T3E01092040	OIL SEAL 25X44X7	1	
7	T3E01011230	NEEDLE BEARING 6202	1	

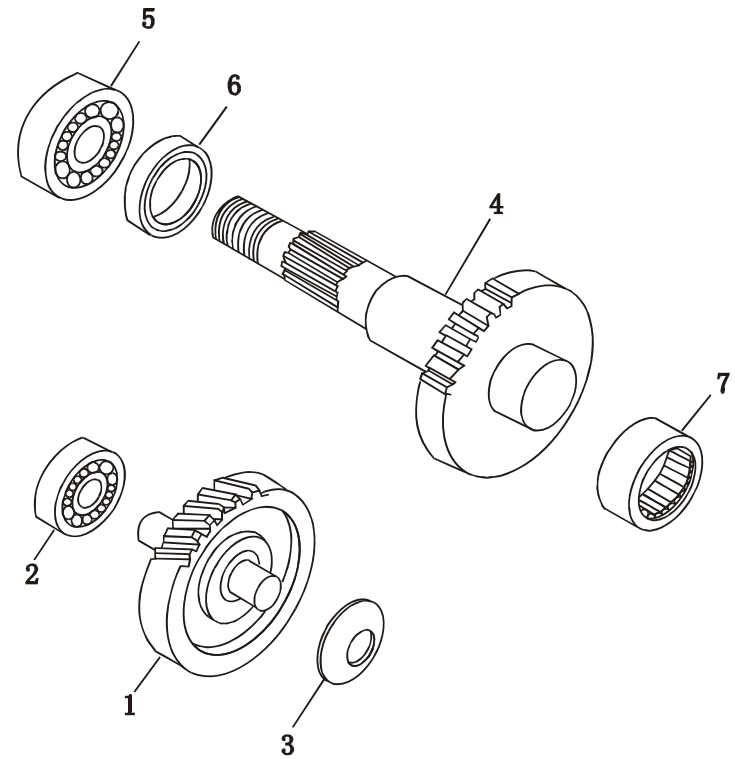

进气阀分总成

REED VALVE ASSY

序号	代码		数量	备注
NO	CODE	DESCRIPTION	QTY	RMK
1	T3E01060000	REED VALVE ASSY	1	双开、正常
2	T3E01060010	REED VALVE	2	
3	T3E01060020	REED VALVE STOPPER	2	
4	GB/T818-2000	SCREW M3×8	4	
5	GB/T93-87	WASHER	4	
6	T3E01060030	VALVE SEAT GASKET	1	非石棉
7	T3E01060040	VALVE SEAT	1	
8	T3E01060050	REED VALVE GASKET	2	

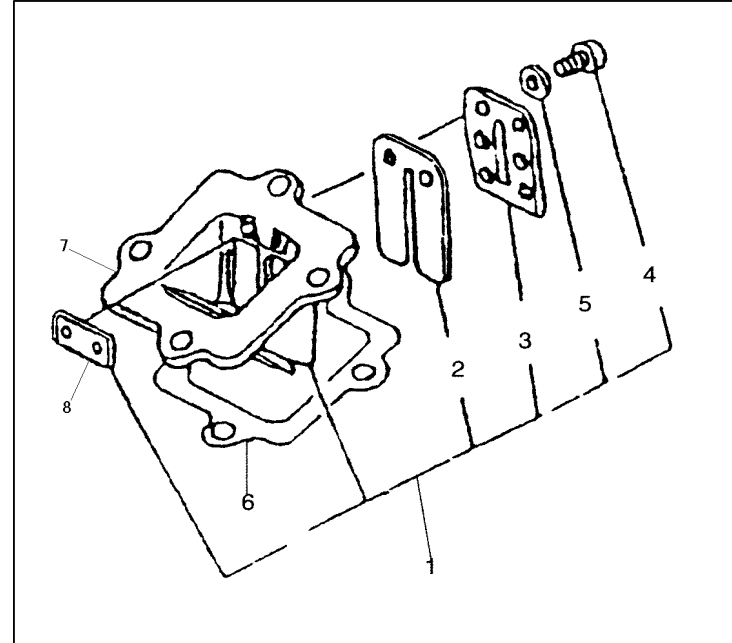

磁电机总成

MAGNETO ASSY

序号	代码		数量	备注
NO	CODE	DESCRIPTION	QTY	RMK
1	T3E01131030	STATOR ASSY	1	
2	T3E01131010	COIL GROUP	1	
3	T3E01131040	PULSE TRIGGER	1	
4	T3E01131050	OIL SEAT	1	
5	GB/T818-2000	SCREW M5X25	2	镀彩锌
6	GB/T818-2000	SCREW M5X12	2	镀彩锌
7	GB/T818-2000	SCREW M4X6	1	镀彩锌
8	GB/T93-87	WASHER	1	
9	T3E01131020	ROTOR ASSY	1	17°
10	GB/T97.1-1985	WASHER13X23.5X2.5	1	
11	GB/T6177.2-2000	NUT M12X1.25	1	镀彩锌
12	GB9074.4-1988	SCREW M6X16	2	镀彩锌
13	GB/T93-87	WASHERΦ5	4	

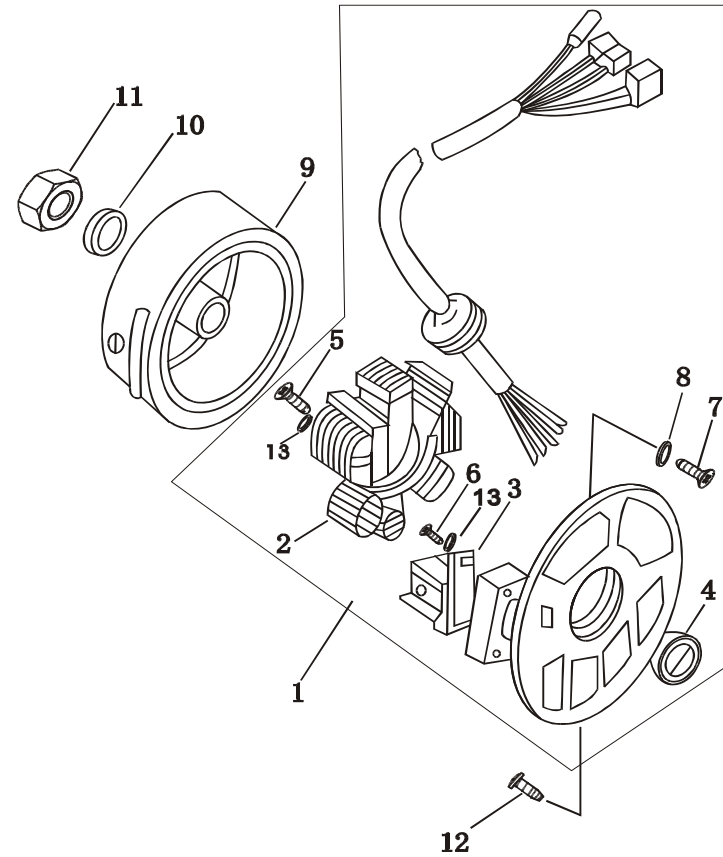

化油器分总成

CARBURETOR ASSY

序号	代码	DESCRIPTION	数量	备注
NO	CODE	DESCRIPTION	QTY	RMK
1	T3E01120010	FIX SCREW	1	
2	T3E01120020	INSTRANT PIPE	1	
3	GB/T818-2000	SCREW	2	
4	GB/T93-87	WASHER	2	
5	T3E01121030	CAP	1	
6	T3E01121040	GASKET	1	
7	T3E01121050	SPRING , return	1	
8	T3E01121060	CLIPMM,V shape	1	
9	T3E01121070	CLIP	1	
10	T3E01121080	NEEDLE, jet	1	(从上往下第二格 25KM) (第三格 30/45KM)
11	T3E01121090	VALVE,PISTON (25KM/32mm)	1	32mm (25KM)
		VALVE,PISTON (30/45KM/28mm)	1	28mm (30/45KM)
		VALVE, PISTON	1	
12	T3E01121100	SCREW, idle speed	1	
13	T3E01121110	SPRING, speed screw	1	
14	T3E01121120	WASHER, speed screw	1	
15	T3E01121130	O RING, speed screw	1	
16	T3E01121140	SCREW, air	1	
17	T3E01121150	SPRING, air screw	1	
18	T3E01121160	WASHER, air screw	1	
19	T3E01121170	O RING, air screw	1	

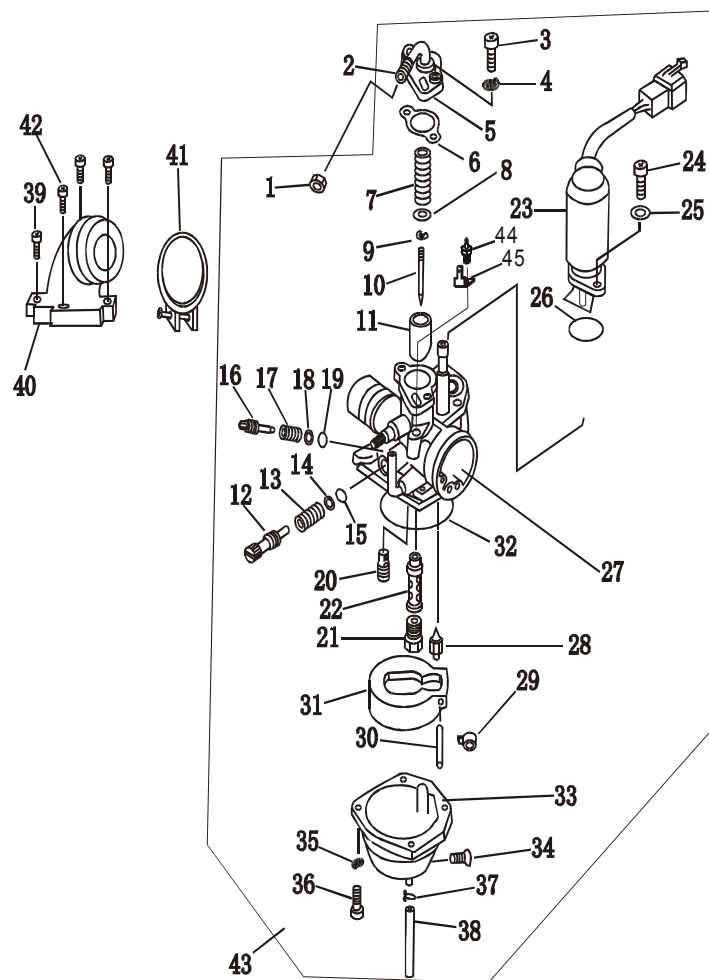

20	T3E01121180	JET, idle(25KM)	1	15 (25KM)
		JET, idle(30/45KM)	1	用于30/45KM

化油器分总成

CARBURETOR ASSY

序号	代码	数量	备注	
NO	CODE	QTY	RMK	
21	T3E01121190	JET, main(45)	1	45 (25/30KM)
		JET, main(47.5)	1	47.5 (45KM)
			1	
			1	
			1	
22	T3E01121200	JET, needle(25KM)	1	426D-9 (25KM)
		JET, needle(30/45KM)	1	30/45KM
23	T3E01121210	1	线长270	
24	GB/T818-2000	2		
25	GB/T93-87	2		
26	T3E01121220	1		
27	T3E01121230	1		
28	T3E01121240	1		
29	T3E01121250	1		
30	T3E01121260	1		
31	T3E01121270	1		
32	T3E01121280	1		
33	T3E01121290	1		
34	T3E01121300	1		
35	GB/T93-87	1		
36	T3E01121310	1		
37	T3E01121320	1		

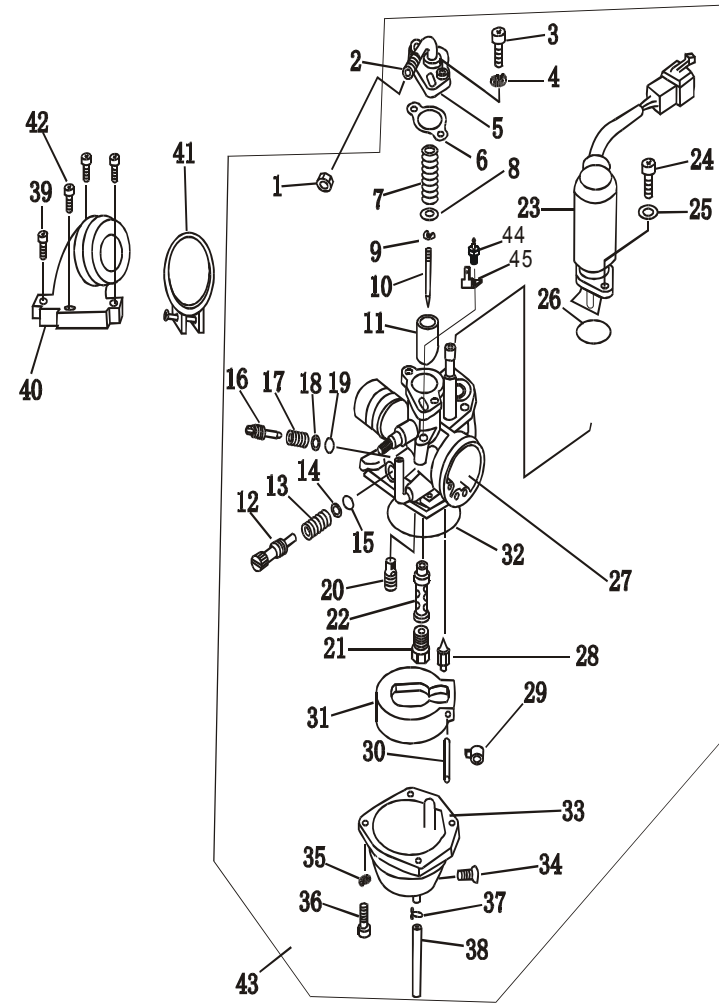

38	T3E01121330	HOSE, drain	1	
39	GB/T70.1-2000	SCREW M6X20	3	不锈钢

化油器分总成

CARBURETOR ASSY

序号	代码	DESCRIPTION	数量	备注
NO	CODE	DESCRIPTION	QTY	RMK
40	T3E01011240	PIPE, intake	1	正常、 φ20/3XG
41	T3E01011300	CLIP(25/30KM)	1	不锈钢(用于25/30KM)
	T3E01011260	CLIP(45KM)	1	用于45KM版
42	T3E01011250	SCREW	1	不锈钢
43	T3E01120000	CARBURETOR ASSY	1	三国(45) (用于25KM版)
		CARBURETOR ASSY	1	三国(45) (用于30KM版)
		CARBURETOR ASSY	1	三国(47.5) (用于45KM版)
44	T3E01121340	HEATING ASSY	1	
45	T3E01121350	L WASHER	1	

